

# AXOMIX

## 5-10



**AXOMATIC**<sup>®</sup>  
group

TUBE FILLING, CARTONING AND PROCESS SOLUTIONS



AXOMATIC Filling and Process Solutions leader da sempre nel settore delle macchine intubatrici, mescolatori sottovuoto e macchine di processo presente sui piú competitivi mercati mondiali ed ha macchine installate nelle piú importanti societ  cosmetiche, farmaceutiche ed alimentari.

Premiata dal costante successo dei propri prodotti, dotati delle piú avanzate tecnologie, quali anticipatori di domande sempre piú sensibili ai contenuti dell'innovazione e della semplicit  di utilizzo e cambio di formato.

Il servizio post vendita qualifica anche sotto il profilo commerciale, l'eccellenza della societ  Axomatic, verso il cliente.



Axomatic has always been a leader in the filling and process solution sector, is present in the most competitive and important world markets and its machines are installed in the most important cosmetic, pharmaceutical and food industries.

The company is proud of the constant success of its product, which are equipped with the most advanced technology and anticipate increasingly more detailed requests concerning innovation.

Even under the sales profile, the after-sales service is proof of the excellent service that Axomatic gives its clients.



AXOMATIC Filling and Process Solutions war schon immer eines der f hrenden Unternehmen im Bereich der Tuben- f ll- und - verschlie maschinen sowie der Misch- und Homogenisieretechnik. Die AXOMATIC Maschinen sind auf allen wichtigsten Weltmaerkten in der kosmetischen, pharmazeutischen, chemischen und Nahrungsmittelindustrie im Einsatz und durch ihr attraktives Preis-/Leistungsverhaeltnis ueberaus konkurrenzfaehig.

AXOMATIC ist durch die konstante Qualitaet und Zuverlaessigkeit seiner Produkte gepraeagt, die stets ueber modernste Technologien verfuegen und bei denen auf Innovation groeften Wert gelegt wird. So ist man bei AXOMATIC auch stets bereit, auf Sonderwuensche des Kunden einzugehen.

Ein weiterer wesentlicher Punkt, den man bei AXOMATIC nie auer acht gelassen hat, ist der Kundenservice, der durch ein weltweites Netz von Vertretungen und Servicetechnikern gewaehrleistet wird.



# AXOMIX 5-10



- ① Turbina veloce di omogeneizzazione
- ② Volantino di ribaltamento recipiente
- ③ Tramoggina per essenze
- ④ Specola e lampada per ispezione recipiente
- ⑤ Allarmi macchina
- ⑥ Pannello di comando con Touch Screen a colori
- ⑦ Sollevamento motorizzato coperchio macchina

Diversi optional sono disponibili, quali:

- valvola di fondo a tre vie
- sistema CIP
- stampa dati
- riscaldamento a vapore
- esecuzioni speciali





- ① Fast homogenising turbine
- ② Manual hand wheel for vessel tilting
- ③ Small hopper for additive, perfumes etc.
- ④ Observation window with windscreen and lamp
- ⑤ Light for machine alarm
- ⑥ Control panel with colour Touch Screen
- ⑦ Machine lid motorized lifting

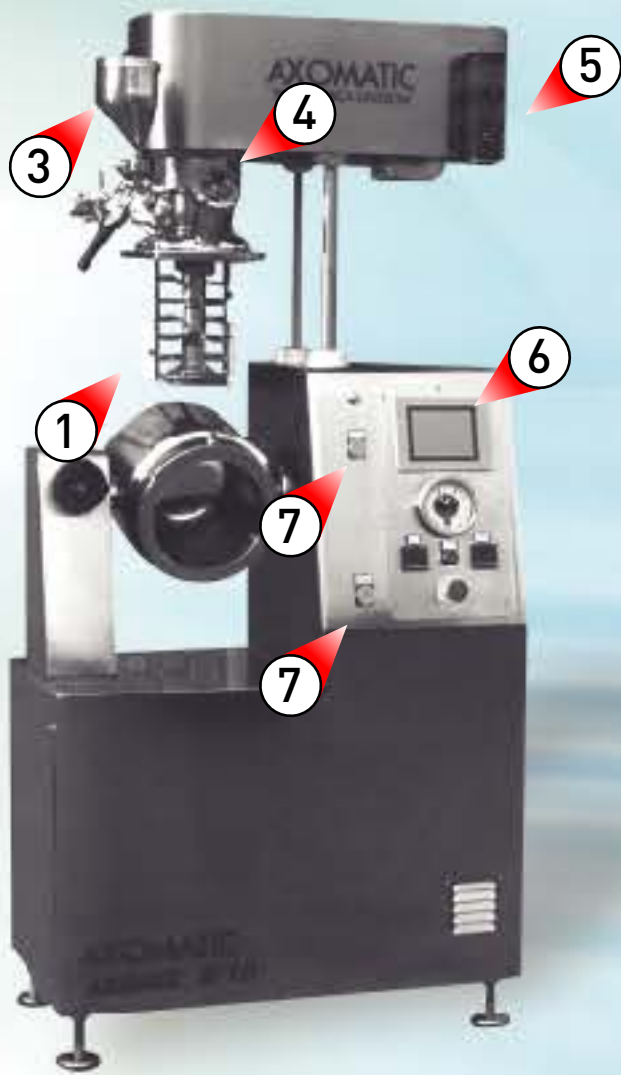

Several optional features available, as:

- Three-ways bottom valve
- CIP system (Cleaning In Place)
- Data printing
- Steam heating
- Special programs





 VALVOLA DI CARICO / SCARICO RASO BOCCA DI TIPO SANITARIO (OPZIONALE)  
 SANITARY CHARGE / DISCHARGE CENTRAL VALVE (OPTIONAL)



 PALE CONTRO-ROTANTI  
 CONTRA-ROTATING BLADES



 FUSORI DA 5 Lt. A 2000 Lt.  
 PRE-MELTERS FROM 5 UP TO 2000 Lt.



- ① Turbina rápida de homogeneización
  - ② Volante vuelco cuba
  - ③ Tolva pequeña para esencias
  - ④ Mirilla y linterna para inspección cuba
  - ⑤ Indicador alarmas máquina
  - ⑥ Panel de mando con pantalla táctil de colores
  - ⑦ Subida motorizada de la tapa de la máquina
- Varios accesorios opcionales disponibles, como:
- Válvula de fondo a tres vías
  - Sistema CIP (Cleaning in Place)
  - Impresión datos
  - Calentamiento con vapor
  - Ejecuciones especiales



- ① Torax
  - ② Handrad zum Kippen des Kessels
  - ③ Kleiner Vorlagebehälter für Additive, Parfumes
  - ④ Sichtfenster mit Beleuchtung
  - ⑤ Warntlicht für Maschinenstörung
  - ⑥ Funktionstastatur mit berührungsempfindlichem Farbbildschirm
  - ⑦ Automatisches anheben des Kesseldeckels
- Optionen auf Anfrage:
- 3-Wege-Ventil am Kesselboden
  - CIP-Reinigung (Clean-In-Place)
  - Datenausdruck
  - Aufheizen mit Wasserdampf
  - Sonderprogramme



- ① Turbine rapide d'homogénéisation
  - ② Volant de renversement du récipient
  - ③ Trémie pour charger les essences
  - ④ Hublot et lampe pour le contrôle visuel
  - ⑤ Indicateur des alarmes de la machine
  - ⑥ Panneau de commandes couleurs avec touches sensibles
  - ⑦ Levage motorisé du couvercle du récipient
- Différentes options sont disponibles telles que:
- Vanne de fond de cuve 3 voies
  - Système CIP (Nettoyage en place)
  - Impression des données de production
  - Chauffage par la vapeur
  - Exécutions spéciales

## AXOMIX 5-10

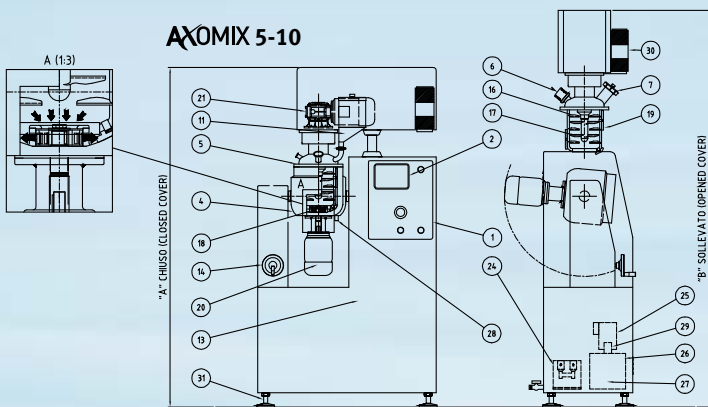

## AXOMIX 5-10

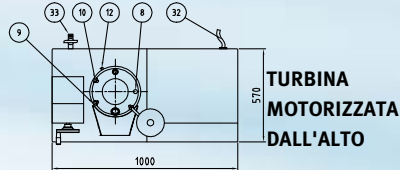
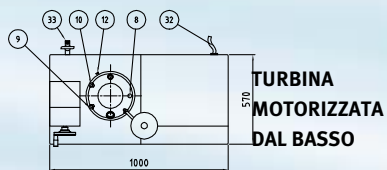
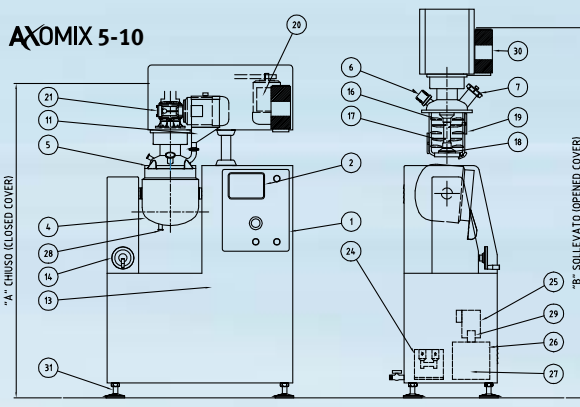

# AXOMIX 5-10

- 1 PANNELLO DI COMANDO
- 2 TOUCH SCREEN PER LE FUNZIONI DELLA MACCHINA
- 3
- 4 RECIPIENTE PRODOTTO
- 5 COPERCHIO
- 6 LAMPADA PER ILLUMINAZIONE INTERNA RECIPIENTE (DN32)
- 7 SPECOLA CON TERGICRISTALLO PER ISPEZIONE RECIPIENTE (DN65)
- 8 ATTACCO PER VUOTO SUL COPERCHIO (T.C. 3/4")
- 9 ATTACCO PER ASPIRAZIONE POLVERI DALL'ALTO (T.C. 3/4")
- 10 ATTACCO PER ASPIRAZIONE LIQUIDI DALL'ALTO (T.C. 3/4")
- 11 TRAMOGGINA ESSENZE (T.C. 3/4")
- 12 SCARICO ACQUA
- 13 SOLLEVAMENTO MOTORIZZATO
- 14 VOLANTINO PER RIBALTAMENTO RECIPIENTE
- 15
- 16 PALE MESCOLAZIONE LENTA da 10 a 75 giri/min
- 17 PALE MESCOLAZIONE VELOCE da 20 a 150 giri/min
- 18 TURBINA da 300 a 3000 giri/min
- 19 RASCHIANTI
- 20 MOTORE TURBINA
- 21 MOTORIDUTTORE MESCOLAZIONE
- 22
- 23 MOTORIDUTTORE SOLLEVAMENTO
- 24 POMPA DEL VUOTO AD ANELLO LIQUIDO
- 25 POMPA PER RICIRCOLO ACQUA (INOX)
- 26 BACINELLA PORTA RESISTENZE PER RISCALDAMENTO PRODOTTO
- 27 RESISTENZE RISCALDAMENTO ACQUA
- 28 SONDA TEMPERATURA PRODOTTO
- 29 SONDA TEMPERATURA ACQUA
- 30 INDICATORE ALLARMI MACCHINA
- 31 PIEDI REGOLABILI
- 32 CAVO PER CONNESSIONE ELETTRICA
- 33 RUBINETTO PER CONNESSIONE IDRAULICA

- 1 CONTROL PANEL
- 2 TOUCH-SCREEN DISPLAY FOR MACHINE FUNCTIONS
- 3
- 4 VESSEL
- 5 COVER
- 6 LIGHT FOR INTERNAL ILLUMINATION (DN32)
- 7 INSPECTION GLASS WITH WHIPER (DN65)
- 8 VACUUM CONNECTION ON THE COVER (T.C. 3/4")
- 9 POWDER CONNECTION ON THE COVER (T.C. 3/4")
- 10 LIQUID CONNECTION ON THE COVER (T.C. 3/4")
- 11 SMALL HOPPER FOR ADDITIVE, PARFUMES etc. (T.C. 3/4")
- 12 WATER DISCHARGE
- 13 COVER LIFTING MOTOR
- 14 MANUAL HANDWHEEL FOR VESSEL TILTING
- 15
- 16 COUNTER-ROTATING BLADES AGITATOR 10-75 rpm
- 17 ROTATING BLADES AGITATOR 20-150 rpm
- 18 TURBINE FOR FAST AGITATOR 300-3000 rpm
- 19 SCRAPERS (PTFE MADE)
- 20 TURBINE MOTOR
- 21 MOTOR REDUCTION GEAR FOR SLOW MIXING
- 22
- 23 MOTOR REDUCTION GEAR FOR VESSEL COVER LIFTING
- 24 WATER RING VACUUM PUMP
- 25 WATER RECIRCULATION PUMP (STAINLESS STEEL)
- 26 WATER TANK FOR HEATING SYSTEM
- 27 HEATING ELEMENTS
- 28 PROBE PRODUCT TEMPERATURE CONTROL
- 29 PROBE WATER TEMPERATURE CONTROL
- 30 LIGHT FOR MACHINE ALARMS
- 31 FOOT SILENT BLOCK
- 32 ELECTRIC CONNECTION CABLE
- 33 WATER CONNECTION

CONSUMO ACQUA PER POMPA DEL VUOTO / WATER CONSUMPTION FOR VACUUM PUMP  
 POTENZA INSTALLATA / INSTALLED POWER  
 MOTORE MESCOLAZIONE / MOTOR FOR SLOW MIXING  
 MOTORE TURBINA / TURBINE MOTOR

2-4 L/min a/at 1 Bar  
 8,5 kW 18A 400V 50Hz  
 0,75 kW  
 1,1 kW

POMPA DELL'ACQUA / WATER RECIRCULATION PUMP  
 MOTORE SOLLEVAMENTO / COVER LIFTING MOTOR  
 POMPA DEL VUOTO / VACUUM PUMP  
 RESISTENZE RISCALDAMENTO / HEATING ELEMENT

0,45 kW  
 0,26 kW  
 0,75 kW  
 3,0 kW

	"A"	"B"	Peso-Weight
AXOMIX 2 Lt	1800	2030	190 kg
AXOMIX 5 Lt	1800	2120	200 kg
AXOMIX 10 Lt	1835	2175	250 kg
AXOMIX 15 Lt	1890	2300	260 kg



# AXOMATIC<sup>®</sup> group

**TUBE FILLING, CARTONING AND PROCESS SOLUTIONS**

**STABILIMENTO E UFFICI:**

VIA EINSTEIN, 8 - I-20019 SETTIMO MILANESE (MI) - ITALY

TEL. +39-02-328.53.70 - FAX +39-02-335.02.894

E-mail: [sales@axomatic.com](mailto:sales@axomatic.com) - Web site: [www.axomatic.com](http://www.axomatic.com)

Skype: [axomatic.sales](https://www.skype.com/name/axomatic.sales)

Diritti riservati a termine di legge - Riproduzione anche parziale vietata  
AXOMATIC<sup>®</sup> si riserva di apportare qualsiasi modifica ritenuta migliorativa senza alcun preavviso

